



The eBike Display  
**User Manual**

**KD21C-P**

# Contents

Product name and model.....	1
Specifications.....	1
Appearance and dimension.....	1
Function and button definition.....	2
◆Function summary.....	2
◆Function layout.....	2
◆Button definition.....	2
Installation.....	3
General operations.....	3
◆Switch E-bike system ON/OFF.....	3
◆Display interface.....	3
◆Switch push-assistance mode ON/OFF.....	4
◆Switch lighting ON/OFF.....	4
◆Assist level selection.....	4
◆Battery indicator.....	5
◆Error code indication.....	5
General Settings.....	6
◆Trip distance clearance.....	6
◆Backlight brightness.....	6
◆Toggle the unit KM/miles.....	7
General parameters settings.....	7
◆Wheel diameter.....	7
◆Speed limit.....	7
Personalized parameters settings.....	8
◆Battery power bar settings.....	9
◆Assist level settings.....	9
Assist level mode options.....	9
Assist level ratio settings.....	10
◆Controller over-current cut settings( <b>optional</b> ).....	10
◆Power assist sensor settings( <b>optional</b> ).....	11
PAS direction settings.....	11
PAS sensitivity settings.....	11
PAS magnet quantity settings.....	12

◆ Speed sensor settings( <b>optional</b> ).....	12
◆ Throttle function settings( <b>optional</b> ).....	13
Throttle- 6km enable/disable settings.....	13
Throttle-PAS enable/disable settings.....	13
◆ System settings ( <b>optional</b> ) .....	14
Battery power delay time settings.....	14
Maximum speed limits.....	14
Button- 6km enable/disable settings.....	15
Slow start up settings.....	15
◆ Power-on password settings.....	16
Power-on password Enable/Disable.....	16
Power-on password change.....	16
◆ Exit settings.....	17
Recover default settings.....	17
Quality assurance and warranty scope.....	18
Wire connection layout.....	18
Warnings.....	19
Attached list 1: Error code definitions.....	20
Attached list 2: Personalized settings symbols.....	20
Attached list 2: Assist level ratio defaults.....	20
Attached list 4: Other symbols.....	21

## Product name and model

E-bike Intelligent LCD

Model: KD21C-P

## Specifications

- 24V/36V/48V Power Supply
- Rated working current: 10mA
- The maximum working current: 30mA
- Off-state leakage current: <math><1\mu\text{A}</math>
- Working temperature:  $-20^{\circ}\text{C} \sim 60^{\circ}\text{C}$
- Storage temperature:  $-30^{\circ}\text{C} \sim 70^{\circ}\text{C}$

## Appearance and Size

Product appearance and dimensional drawing (unit: mm)

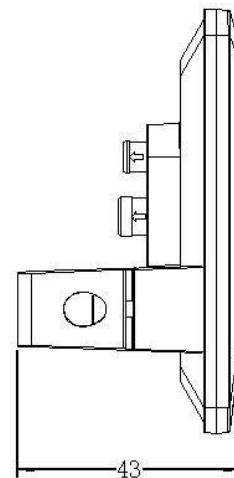
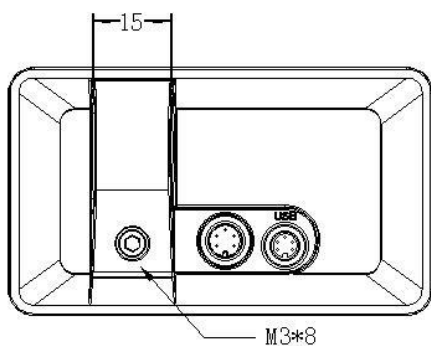
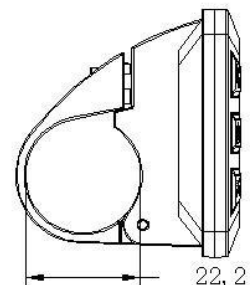
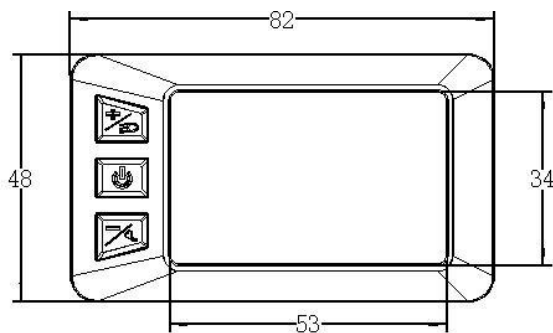

**\*Display side is cable free. USB Port is optional**

## Function and Button Definition

### ◆Function Summary

KD21C-P has many functions to meet riders' needs. The indication elements are as follows:

- Battery level
- Motor output power
- Assist level
- Speed indication (incl. current speed, Max. speed and Avg. speed)
- ODO and Trip
- Push-assistance function
- Trip time
- Backlight ON/OFF
- Error code indication
- Various Parameters Settings (e.g. wheel diameter, speed limit, battery power bar, assist level, current limit, password enable, etc.)
- Recover Default Settings

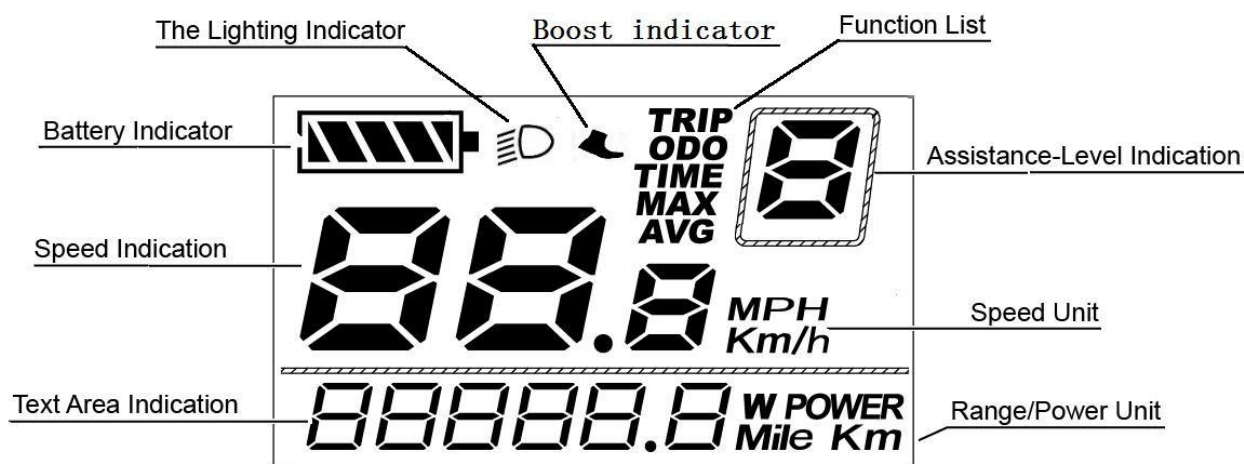

### ◆Function layout



Functional Area Distribution

### ◆Button Definition

There are three buttons (  ,  ,  ) on KD21C-P display. In this manual, we use words

ON/OFF, UP, DOWN to represent these 3 symbols (  ,  ,  ) .



### ◆Switching Push-assistance mode ON/OFF

To activate the push-assistance function, press and hold the **DOWN** button. After 2 seconds, E-bike is activated to go at a uniform speed of 6 Km/h while the screen displays “ P ”.

The push-assistance function will be switched off as soon as you release the **DOWN** button.

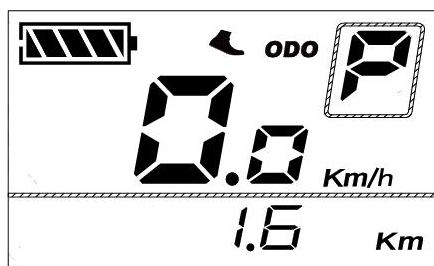

Push-assistance mode

■Push-assistance function may only be used when pushing the E-bike. Be aware of danger of injury when bike wheels do not have ground contact while using the push-assistance function.

### ◆Switching Lighting ON/OFF

To switch on E-bike front light or rear light, press the “**UP**” button for 2s. The display backlight brightness is automatically reduced while the screen displays “ ”.

Likewise, press the “**UP**” button for 2s again, the bike front light and rear light can be switched off and display backlight recover its brightness.

\*If E-bike light is independent of “**UP**” button, the “**UP**” button can only be used to switch on/off the display backlight.

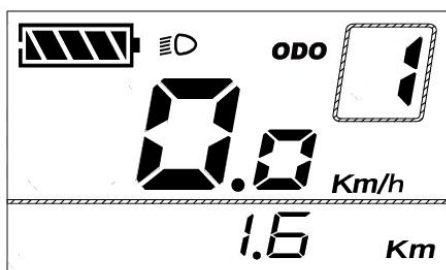

Switching Lighting on/off

### ◆Assist Level Selection

The assist level of the E-bike drive can be changed anytime, even during riding.

The assist level ranges from 0 to 5 (level 0 to level 5). The default assist level is “1” when the display is started. The output power is zero on Level “0”. Level “1” is the minimum output power. Level “5” is the maximum output power.

Press **UP/DOWN** button to switch between the E-bike system assist levels and change the motor output power.

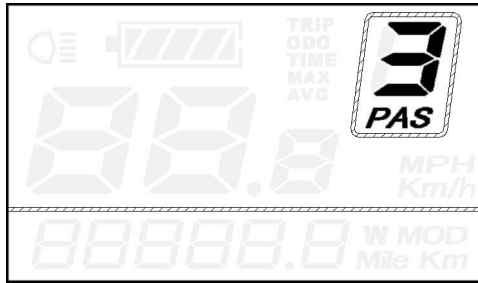

Assist Level “3”

◆ **Battery Indicator**

The five battery power bars represent the capacity of the battery. The five battery bars are bright when the battery is in full voltage. When the battery is in low voltage, battery frame will flash at the frequency of 1HZ to give a notice that the battery needs to be recharged immediately

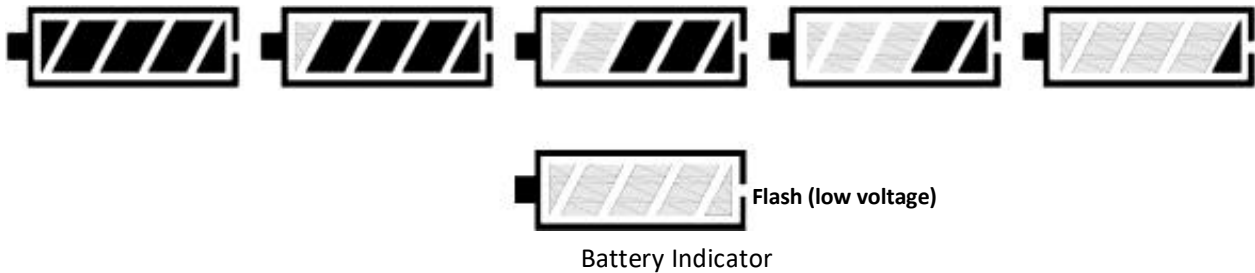

◆ **Error Code Indication**

The components of the E-bike system are continuously and automatically monitored.

When an error is detected, the respective error code is indicated in text indication area.

Refer to detailed definition of the error codes in **Attached list 1**.

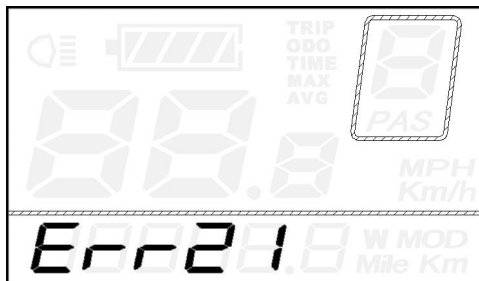

Error Code Indication

■ **Have the display inspected and repaired when an error code appears. Or else, you will not be able to ride the bike normally. Please always refer to an authorized bicycle dealer.**



## General Settings

After the E-bike system is switched on, hold both the **UP** button and **DOWN** button simultaneously for 2s to access general settings menu.

■ All the settings are done to a stationary E-bike.

### ◆ Trip Distance Clearance

**TC** represents trip distance clearance settings.

Press the **UP/DOWN** button to choose Y or N. The default value is N.

To store a changed setting, press the **ON/OFF** button and access backlight settings.

For symbols and their definitions, please refer to **Attached list 4**.

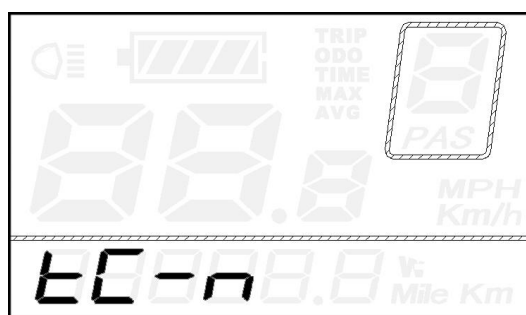

Trip Distance Clearance Settings Interface

### ◆ Backlight settings

**bL** represents backlight settings. Level "1" is the lowest brightness. Level "2" is the medium brightness. Level "3" is the highest brightness. The default value is "1".

To change the backlight brightness, press the **UP/DOWN** button to increase or decrease until the desired brightness is displayed.

To store a changed setting, press the **ON/OFF** button and access unit toggling settings.

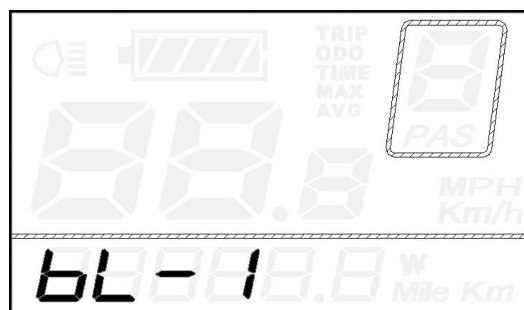

Backlight Brightness Setting Interface

### ◆Unit km/mi toggling

U represents unit settings, “1” is mile, and “2” is kilometer. The default value is “2”.

To toggle the unit, press the **UP/DOWN** button until the desired unit is displayed.

To store a changed setting, press the **ON/OFF** button and access trip distance clearance settings again or hold the **ON/OFF** button for 2s to exit **General Settings**.

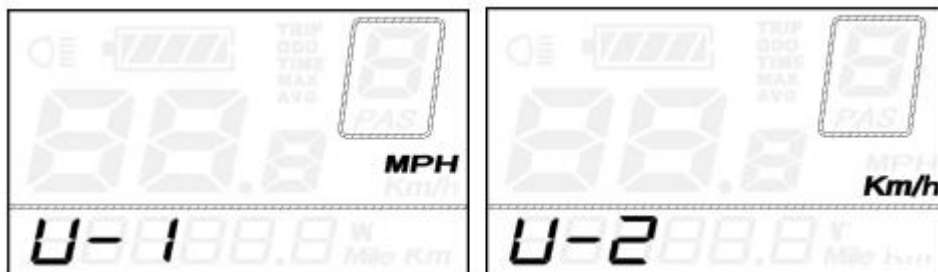

Mile and Kilometer toggling Settings Interface

### General Parameter Settings

To access general parameter settings interface, hold both the **UP** and the **DOWN** button simultaneously for 2s to enter **General Settings**, then hold both the **DOWN** and **ON/OFF** button for 2s again to enter **General Parameter Settings**.

#### ◆Wheel Diameter Settings

Ld represents wheel diameter settings. Optional values are 16, 18, 20, 22, 24, 26, 700C and 28. The default value is 20 inch.

Press the **UP/DOWN** button to increase or decrease wheel diameter until the desired value is displayed.

To store a changed setting, press **ON/OFF** button and access speed-limit settings interface.

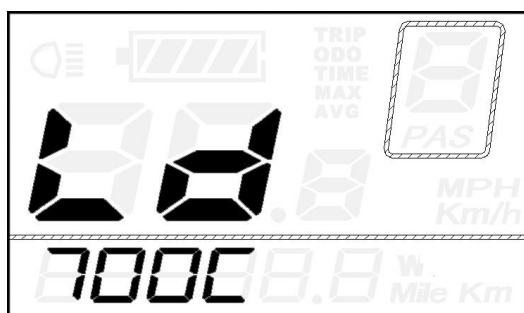

Wheel Diameter Settings Interface

#### ◆Speed limit Settings

LS represents the speed limit settings. When the current speed is faster than speed limit, the E-bike system will be switched off automatically. Speed limit ranges from 12Km/h to 40Km/h. The default value is 25Km/h.

Press the **UP/DOWN** button to increase or decrease the speed limit values until the desired one is displayed.

To store a changed setting, press **ON/OFF** button and access wheel diameter setting again or hold the **ON/OFF** button for 2s to exit **General Parameter Settings**.

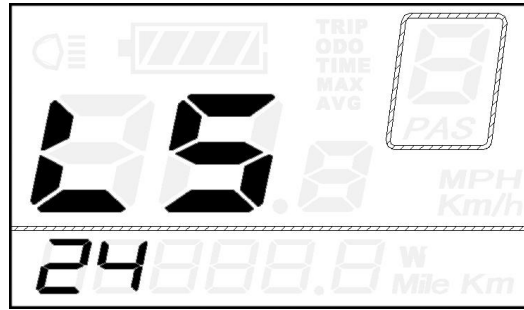

Speed Limit Settings Interface

## Personalized Parameter Settings

**Personalized Parameter Settings** can meet a variety of riders' personalized requirements. 8 settings are Battery Power Bar Settings, Power assist level Settings, Over-current Cut Settings, Power Assist Sensor Settings, Speed Sensor Settings, Throttle Function Settings, System Settings and Power-on Password Settings. Please refer to **Attached list 2** for the definition of the symbols.

Hold **UP** and **DOWN** button simultaneously for 2 seconds to enter **General Settings** and Hold **UP** and **DOWN** button simultaneously for another 2 seconds to enter **Personalized Parameter Settings** interface.

Press **UP** or **DOWN** button to choose the personalized parameter setting item, then press **ON/OFF** button to enter the corresponding setting interface.

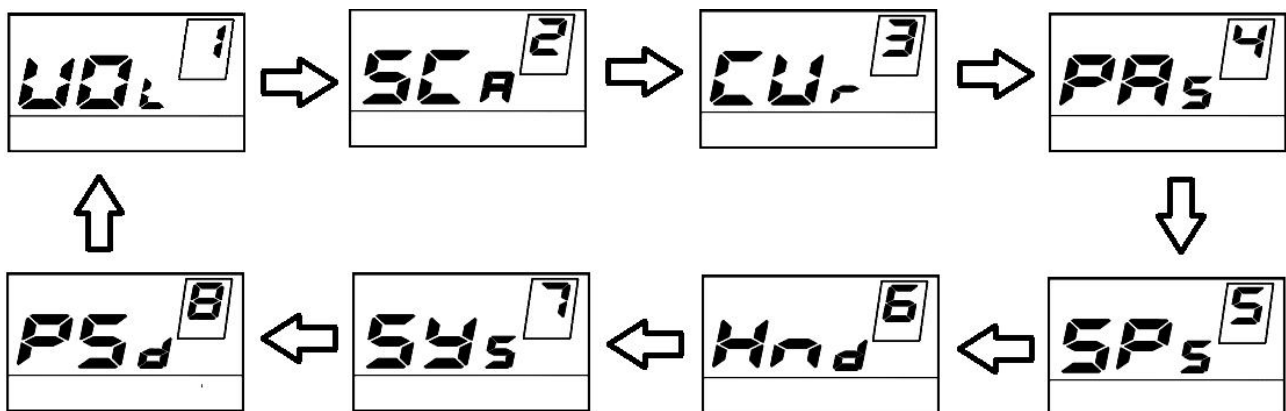

Setting Item Cycle Interface

## ◆ Battery Power Bar Settings

**VOL** represents voltage settings. Each bar represents a voltage value. Each of the 5 values is to be entered one by one. For example, VOL 1 is the first bar voltage value, the default value is 31.5V. Press **UP** or **DOWN** button to increase or decrease the bar value and press **ON/OFF** button to store a changed setting and access the second bar. Likewise, you can set the values in the same manner for other bars. After values for 5 bars are entered completely, press **ON/OFF** to confirm and return to the previous menu.

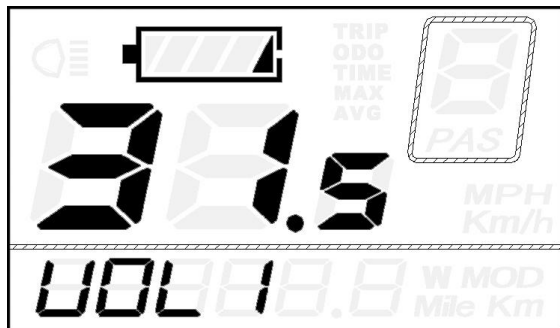

Battery Bar Settings

## ◆ Assist Level Settings

**SCA** represents assist level settings.

### Assist Level mode options

There are 8 assist level modes: 0-3, 1-3, 0-5, 1-5, 0-7, 1-7, 0-9, 1-9. The default mode is 0-5.

Press the **UP/DOWN** button to increase or decrease until the desired mode is displayed.

Press the **ON/OFF** button and access the assist level ratio settings automatically.

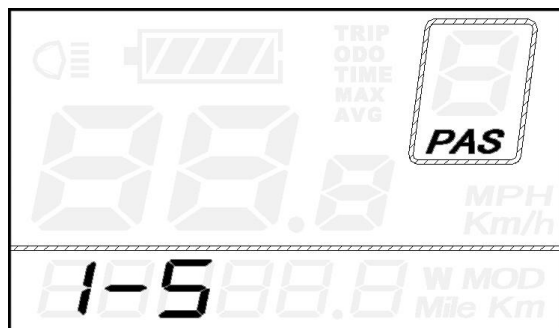

"1-5" flash

Assist Level Mode Interface

### Assist Level Ratio Settings

The speed of each level can be adjusted to meet different riders' needs by setting the ratios.

For example, the default ratio is 50% for level "1"; the ratio range is 45%-55% for Level "1".

To change the ratio of a certain assist level, press the **UP/DOWN** button to choose the desired ratio value, and then press the **"ON/OFF"** button to confirm and then move to the next level ratio setting.

After ratios of all levels were input, hold the **"ON/OFF"** button for 2s to confirm and return to previous menu.

\*Please refer to assist level ratio default values **Attached list 3**

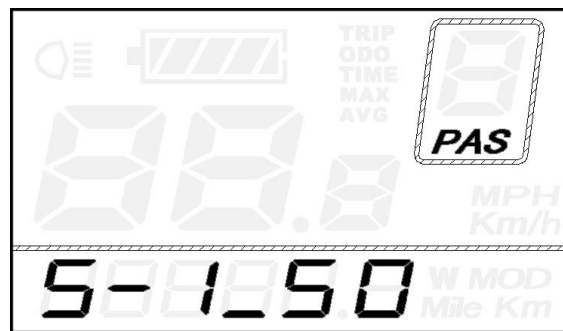

Assist Level Ratio Interface

### ◆ Controller Over-Current Cut Settings

**CUR** represents controller over-current cut settings. CUR value ranges from 7.0A to 22.0A. The default value is 15A.

Press the **UP/DOWN** button to increase or decrease the value of the current.

Press the **ON/OFF** button and then return to previous menu.

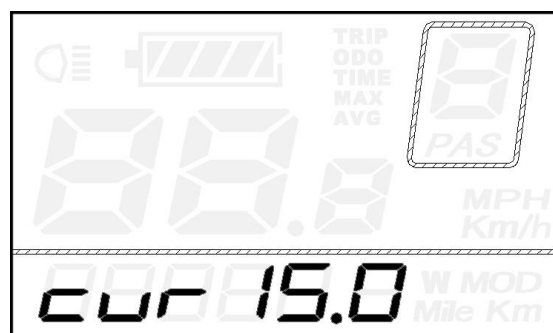

Current Settings Interface

## ◆ Power Assist Sensor Settings

PAS represents power assist sensor settings.

### *Power Assist Sensor Direction Settings*

“run-F” means forward direction while “run-b” means backward direction. The default value is “run-F”.

Press the **UP/DOWN** button to select **F** or **b** to change the direction of Power Assist Sensor.

Press the **ON/OFF** button and then access PAS sensitivity settings.

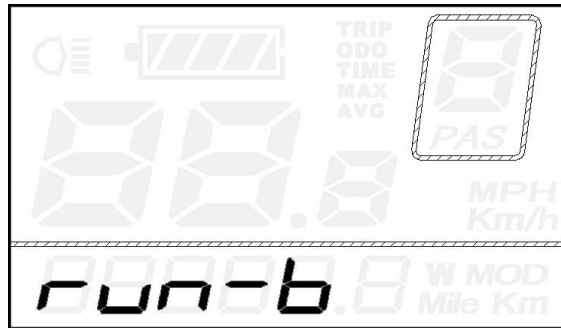

PAS Direction Settings

### *PAS Sensitivity Settings*

SCN represents PAS sensitivity settings. The sensitivity value ranges from “2” to “9”. “2” is the strongest, “9” is the weakest. The default value is “2”.

Press the **UP/DOWN** button to choose sensitivity value to change the PAS sensitivity settings.

Press the **ON/OFF** button and then access magnet disk settings.

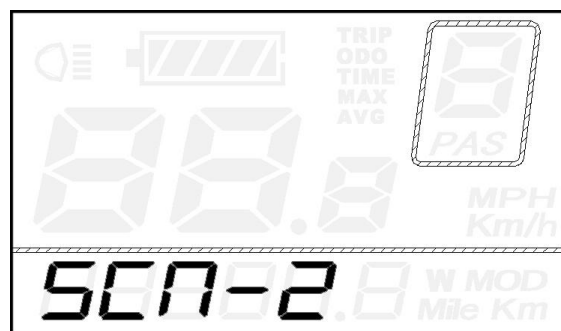

PAS sensitivity Settings

### **PAS Magnet Quantity Settings**

**N** represents the number of magnets on PAS disk. The default value is 12.

Press the **UP/DOWN** button to select the number of magnets on PAS disk.

Hold the **ON/OFF** button for 2s to confirm and return to previous menu.

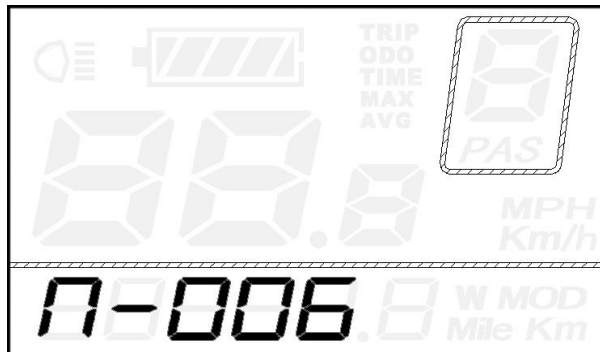

PAS Disk Magnet Quantity settings

### **◆ Speed Sensor Settings**

**SPS** represents speed sensor settings. The default value is 1.

Press the **UP/DOWN** button to choose the number of spoke magnets on the bike wheel. The range is from 1 to 9.

Hold the **ON/OFF** button for 2s to confirm and then return to previous menu.

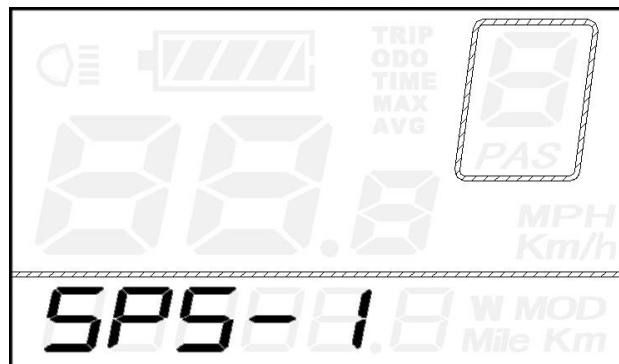

Speed Sensor settings

## ◆Throttle Function Settings

### *Throttle- 6km Enable/Disable settings*

**HL** represents throttle push-assistance function. **HL-N** means throttle push-assistance function is disabled. **HL-y** means throttle push-assistance function is enabled. The default value is **HL-N**.

Press the **UP/DOWN** button to select **Y** or **N** to enable or disable throttle push-assistance function .

To enable throttle push-assistance, select **Y** and hold **ON/OFF** button for 2s to confirm and return to previous menu.

To disable throttle push-assistance, select **N** and access Throttle Level Enable/Disable Setting below

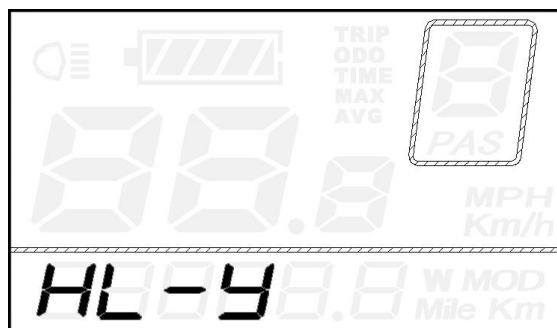

Throttle Push-assistance Enable/Disable Interface

### *Throttle- PAS Enable/Disable settings*

**HF-y** means throttle speed is limited by current power assist level while **HF-n** means throttle speed is not limited by current power assist level. The default value is **n**. Press **UP/DOWN** to set **y** or **n**.

If you choose **y**, the maximum speed can only be the highest speed powered by current power assist level when you twist the throttle.

If you choose **n**, the maximum speed is not limited by current power assist level and you can override whatever level you are in and reach rated maximum speed when you twist the throttle.

To store a changed setting, press **ON/OFF** button to confirm and return to throttle push-assistance enable/disable setting interface or hold **ON/OFF** button for 2s to confirm and return to previous menu.

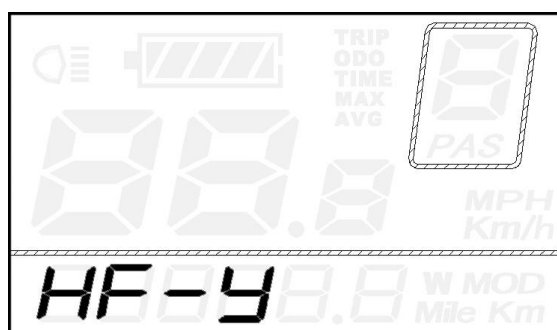

Throttle Level Enable or Disable Interface



## ◆System Settings

### *Delay time settings for battery power*

**DLY** represents battery power delay time settings. The default value is 3s.

Press the **UP/DOWN** button to choose delay time 3s, 6s, 12s to change the settings.

Press the **ON/OFF** button to confirm and access the max speed limit settings.

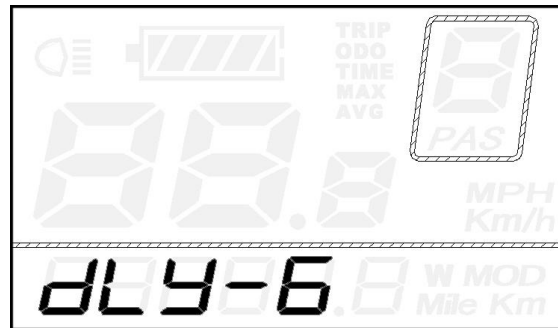

Battery power delay time Interface

### *Max speed limit settings*

**MAX SPD** represents max speed limit settings. The default value is 40Km/h.

Press the **UP/DOWN** button to set the max speed from 25Km/h to 40 Km/h.

Press the **ON/OFF** button to confirm and then access Push-assist settings

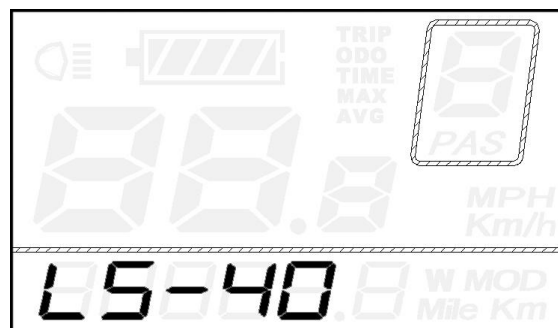

Interface of Max Speed Limit Settings

■ The maximum speed upper limit is set by the display manufacturer.

### **Button- 6km Enable/Disable settings**

PUS represents push-assistance enable/disable settings. “Y” means push-assistance is enabled, “N” means push-assistance is disabled. The default value is “Y”.

Press the **UP/DOWN** button to choose “Y” or “N” to change push-assistance settings.

Press the **ON/OFF** button to confirm and then access slow start up settings.

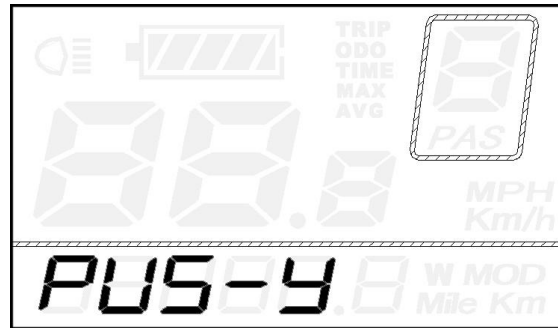

Push-assistance settings Interface

### **Slow Start up Settings**

SSP represents slow start up. The range is “1-4”, “4” is the slowest. The default value is “1”.

To change slow start up settings, press the **UP/DOWN** button to choose the desired value.

Press the **ON/OFF** button and moves to Delay time settings for battery power.

Hold the **ON/OFF** button for 2s to return to previous menu, .

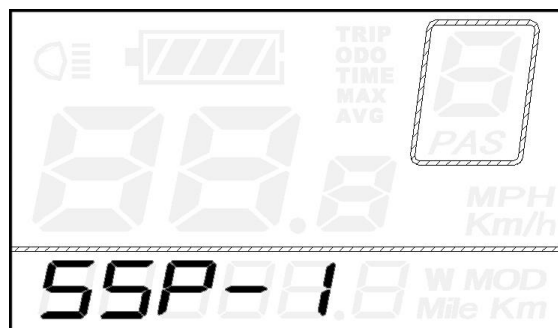

Slow Start-up Settings interface

## ◆ Power-on Password Settings

**PSd** represents power-on password settings. Power-on password is a 4-digit code. The default password is “1212”.

Press **ON/OFF** button to enter the interface where “P2, 0000” is shown on the screen. Please input the current password or default password ‘1212’.

Press **UP/DOWN** button to increase or decrease the number and press **i** button to confirm digits one by one until the correct 4-digit password is completed. Press **ON/OFF** button to access power-on password Enable/Disable Settings.

Otherwise stay in password input state.

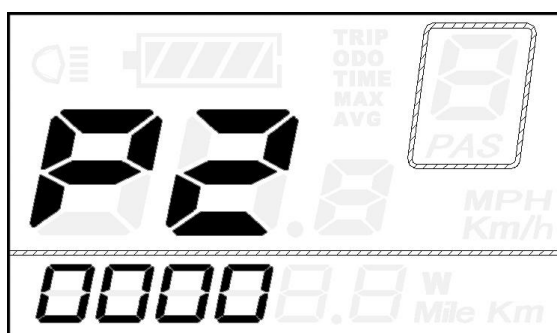

Password Input Interface

### Power-on Password Enable/Disable

Press **UP** or **DOWN** button to choose Y or N and press **i** button to confirm. Y means power-on password is enabled. N means power-on password is disabled. The default value is N.

If you choose Y, press the “i” button and then access power-on password change interface.

If you choose N, you will exit the power-on password settings interface and return to previous menu.

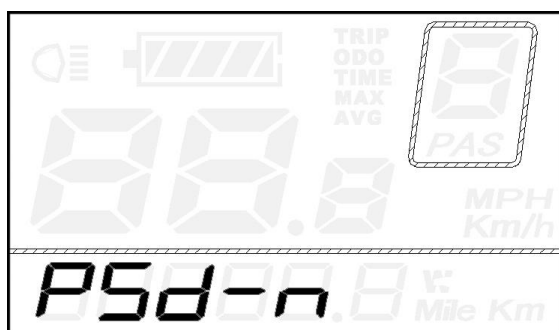

Power-on Password Disable Interface

### Power-on Password Change

When the display shows P3, 0000, press **UP/DOWN** to change the number and then press **ON/OFF** button to confirm digits one by one until a new 4-digit password is completed.

To store the new power-on password, hold **ON/OFF** button for 2 s and then exit settings.

When you switch on the E-bike system next time, the display will show P1,0000, please input the new password to power on.

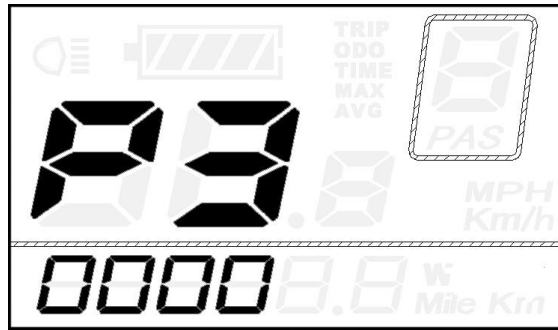

Power-on Password Change Interface

### ◆Exit settings

In personalized parameter settings interface,

Press the **ON/OFF** button is to confirm the input.

Hold the **ON/OFF** button is to store the settings and exit the current setting.

Hold the **DOWN** button is to cancel the operations but not to store setting data and return to previous menu.

■If there is no operations in one minute, the display will exit the settings interface

### Recover default settings

dEF represents recovering default settings. The default value is N.

To access recover default settings, hold both **UP** and **ON/OFF** button for 2s and then access selection interface. Press the **UP/DOWN** button to choose “Y” or “N”. “N” means not recovering default settings. Y means recovering default settings.

When it is “Y”, hold the **ON/OFF** button for 2s to recover default settings, the display shows DEF-00 at the same time and returns to display start-up page .

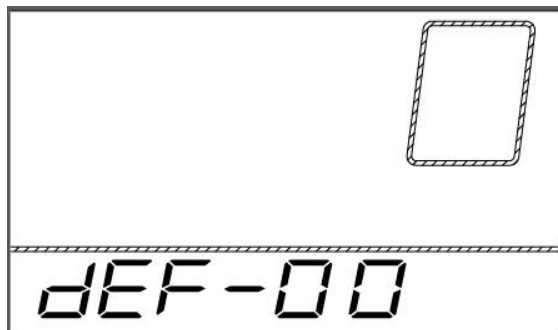

Recover Default Settings Interface

## Quality assurance and warranty scope

### I Warranty

- 1) The warranty will be valid only for products used in normal usage and conditions.
- 2) The warranty is valid for 24 months after the shipment or delivery to the customer.

### II Others

***The following cases do not belong to warranty scope:***

- 1) The display is demolished.
- 2) The damage of the display is caused by wrong installation or operation.
- 3) The shell of the display is broken after the display is out of the factory.
- 4) The cable of the display is broken.
- 5) Beyond warranty period.
- 6) The fault or damage of the display is caused by the force majeure (e.g., fire, earthquake, etc.)

### ◆Connection Layout

Socket type male connector( display is cable free)

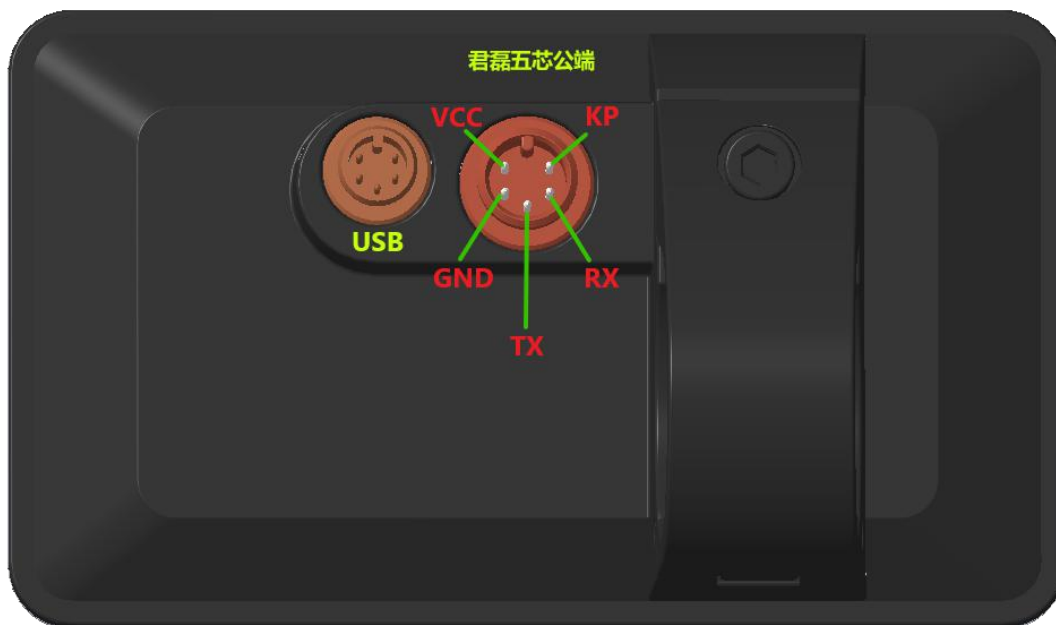

**Julet Male 5 pins.**



**Higo Male 5 pins**

**Wire sequence table( Julet male 5 pins)**

Wire sequence	Pin wire color	Function
1	Red(VCC)	+
2	Blue(K)	Lock
3	Black(GND)	-
4	Green(RX)	RX
5	Yellow(TX)	TX

■ displays have wire connection with water-proof connectors, users can not see the pin wire colors.

**Warnings:**

1. Use the display with caution. Don't attempt to release or link the connector when battery is power on.
2. Try to avoid hitting the display.
3. Don't modify system parameters to avoid parameter disorder.
4. Make the display repaired when error code appears.

■ This manual instruction is a universal version for **DISPLAY KD21C-P**. Some versions of this display may be different from specification to specification as to the software. Please always refer to an actual version.

### Attached list 1: Error code definition

Error Code	Definition
21	Current Abnormality
22	Throttle Abnormality
23	Motor Phase Abnormality
24	Motor Hall Signal Abnormality
25	Brake Abnormality
30	Communication Abnormality

### Attached list 2: Personalized Parameter settings

No.	Settings item	Symbol
1	Battery Power Bar Settings	<i>UD<sub>L</sub></i>
2	Power assistant level Settings	<i>SE<sub>A</sub></i>
3	Over-current Cut Settings	<i>CU<sub>r</sub></i>
4	Power Assistant Sensor Settings	<i>PA<sub>S</sub></i>
5	Speed Sensor Settings	<i>SP<sub>S</sub></i>
6	Throttle Function Settings	<i>HA<sub>d</sub></i>
7	System Settings	<i>SY<sub>S</sub></i>
8	Power-on Password Settings	<i>PS<sub>d</sub></i>

### Attached list 3: Assist level ratio defaults

Level PAS Level mode	Level								
	1	2	3	4	5	6	7	8	9
0-3/1-3	50%	74%	92%	—	—	—	—	—	—
0-5/ 1-5	50%	61%	73%	85%	96%	—	—	—	—
0-7/ 1-7	40%	50%	60%	70%	80%	90%	96%	—	—
0-9/ 1-9	25%	34%	43%	52%	61%	70%	79%	88%	96%

#### Attached list 4: Other symbols

No.	Symbol	Definition
1	EC	Trip distance clearance
2	BL	Backlight
3	U	Unit
4	UOL	Voltage
5	Ld	Wheel diameter
6	LS	Speed limit
7	COF	Controller over-current cut
8	run-b	Backward
9	run-F	Forward
10	SCN	Sensitivity of PAS
11	SPS	Speed sensor
12	dLY	Power delayed time
13	HL	Throttle -6km
14	HF	Throttle-PAS
15	PUS	Button- 6km
16	SSP	Slowly start up
17	PSd	Password
18	DEF	Recover default
19	y	Yes
20	n	No